

# X-30, X-50, X-200, V2000 (1 section) X-300, (2 sections); X-510 (3 sections)

Dual/three/multi-band high performance gain vertical base station antennas

## Description

- All base station antennas employ high performance C-Load structures.
- Newly developed Liner Phase Shifter technology being employed on all antennas permits the antennas to achieve high performance, high power rating, low SWR and broader band coverage.
- The antennas composed of more structures maintain the same strength as those with one piece structure by its overlapping FRP outer-shells. Perfect waterproof being achieved by ring gasket enables the antennas to maintain their performance even during rainy weather. They can be easily assembled or disassembled when it is required, by tightening or loosening the joint bracket accordingly.
- Professional quality maximum wind resistance is achieved by their rugged structure. Superior waterproof structure avoids any possible problems of unstable SWR that could be caused by climatic effects. Rust and corrosion free structure allows the antennas to be installed at seaside or contaminated air environments without any precautions. The bands can be operated simultaneously by using optional antenna duplexers.
- DC ground structure, that avoids high voltage caused by thunder lightings to the ground, protects your radio equipments.

## Adjustment

All these antennas are completely adjustment free. If SWR is extraordinary high, check if each part is properly connected: it is most likely due to bad contact in coaxial cable and/or connector connection or soldering problem. Be sure to use a 50 ohm coaxial cable to feed the antenna.

## Assembling the X-30, X-50 and X-200.

1. Attach three radial elements to the feedpoint section (one piece structure with FRP element out-shell).

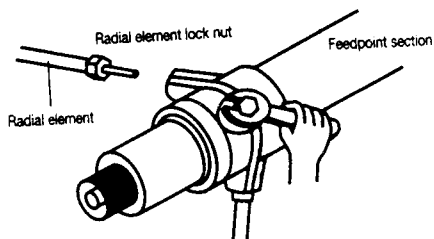

2. Fix two mast brackets to support pipe. Then connect coaxial cable to the feedpoint section through support pipe. Fix support pipe to the feedpoint section with a lock screw by aligning the holes at the bottom of the section and top of the pipe.

3. Attach assembled antenna to a mast by taking whole balance into account and fix it firmly as shown in the following picture.

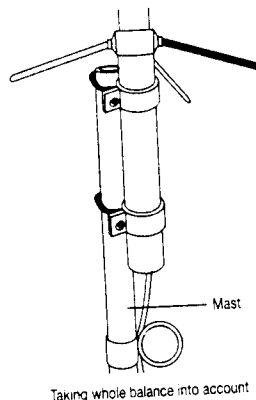

Taking whole balance into account

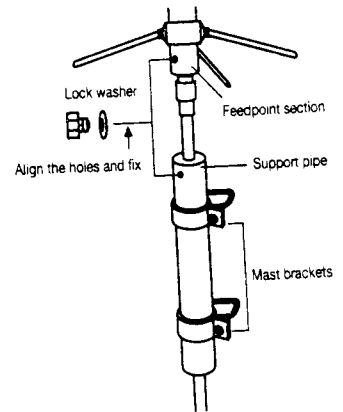

## Assembling the V2000

V2000 differentiates from X-30/X-50/X-200 models because one of its radials is composed of two sections, which must be previously fastened before fixing the other radials to the antenna. The mounting procedure is however the same as the above models.

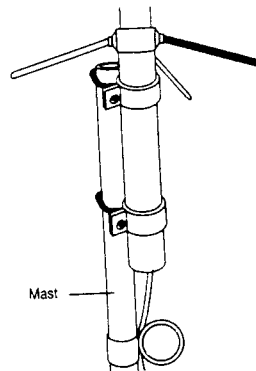

Mast

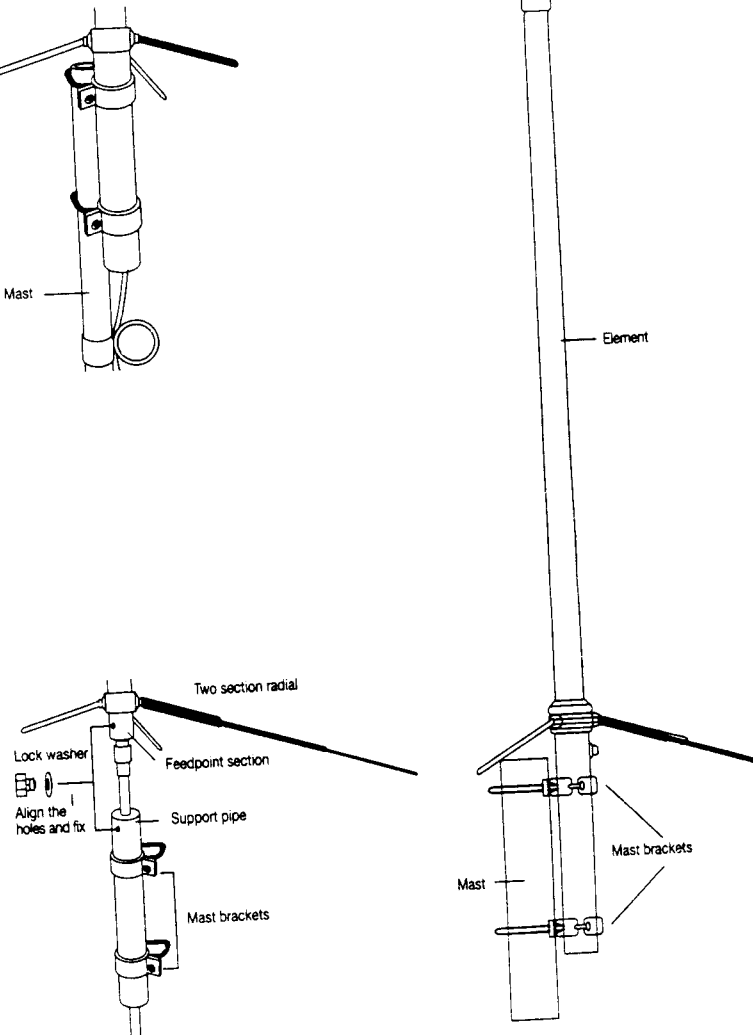

Mast

Element