

ASSEMBLY INSTRUCTIONS

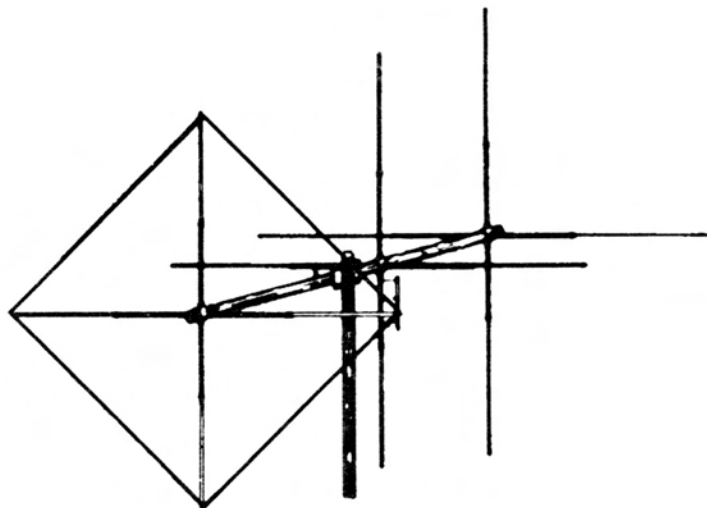

COMET

**SWITCHABLE POLARITY 6 ELEMENT
10/11 METER BEAM**



www.macoantennas.net

(815) 244-3500

MACo Antennas, A Division of Charles Electronics, LLC
302 S. East Street, Mt. Carroll, IL 61053

MACO COMET

PACKING LIST

<u>PART</u>	<u>QTY</u>	<u>OD</u>	<u>SIZE</u>	<u>LENGTH</u>	<u>DESCRIPTION</u>	<u>CHECKLIST</u>
T59P	1	1 1/2"	.050"	72"	ALUM. TUBING SWAGED ONE END	_____
T28	1	1 1/2"	.050"	72"	ALUMINUM TUBING	_____
T11P	6	5/8"	.050"	72"	ALUM. TUBING SLOTTED BOTH ENDS	_____
T01	8	1/2"	.050"	72"	ALUMINUM TUBING	_____
P01P	1		1/4" x 5	5"	1 1/2" BOOM TO 1 1/2" MAST PIPE	_____
W04P	1		7/14	40"	COPPER WIRE	_____
FA1P	4			48"	FIBERGLAS RODS	_____
G01P	2				11 METER GAMMA MATCHES	_____
Z08P	4				GAMMA STRAPS W/COAX CONNECTORS	_____
S42	2				COAX CONNECTOR W/MOUNTING NUT	_____
<u>HARDWARE BAG #1</u>						
U02	10		1 1/2"		PLATED U-BOLTS	_____
S02	10		1 1/2"		PLATED SADDLES	_____
N03	20		5/16"		LOCK NUTS	_____
<u>HARDWARE BAG #2</u>						
BE1P	6		1 1/2"		BOOM TO ELEMENT MOUNT	_____
W58P	12		5/8"		ALUMINUM CLAMPS	_____
PL2	8		.437"		PLASTIC CAPS – BLACK	_____
PL4R	1		1 1/2"		PLASTIC CAP – RED	_____
PL4B	1		1 1/2"		PLASTIC CAP – BLACK	_____
S21	13		10-24	1/2"	MACHINE SCREWS	_____
N11	13		10-24		SQUARE NUTS	_____
N12	7		#10		LOCK WASHERS	_____
N26	7		#10		FLAT WASHERS	_____
Z02P	4		1/2"		GAMMA STRAPS	_____
	1				FIBERGLASS ROD KIT (4 SCREWS)	_____
	1				WARRANTY SHEET	_____
	1				INSTRUCTION SHEET	_____
	1				TIP SHEET	_____

Please note: In an effort to keep the price on Maco Antennas down, we have decided not to clean up all the burrs and rough edges on the parts. We recommend that you deburr and clean up each part with files, sandpaper, etc. so that they go together easily. We are aware this needs to be done but have elected not to do it to save you the money we would have to add to the price of the kit for this service.

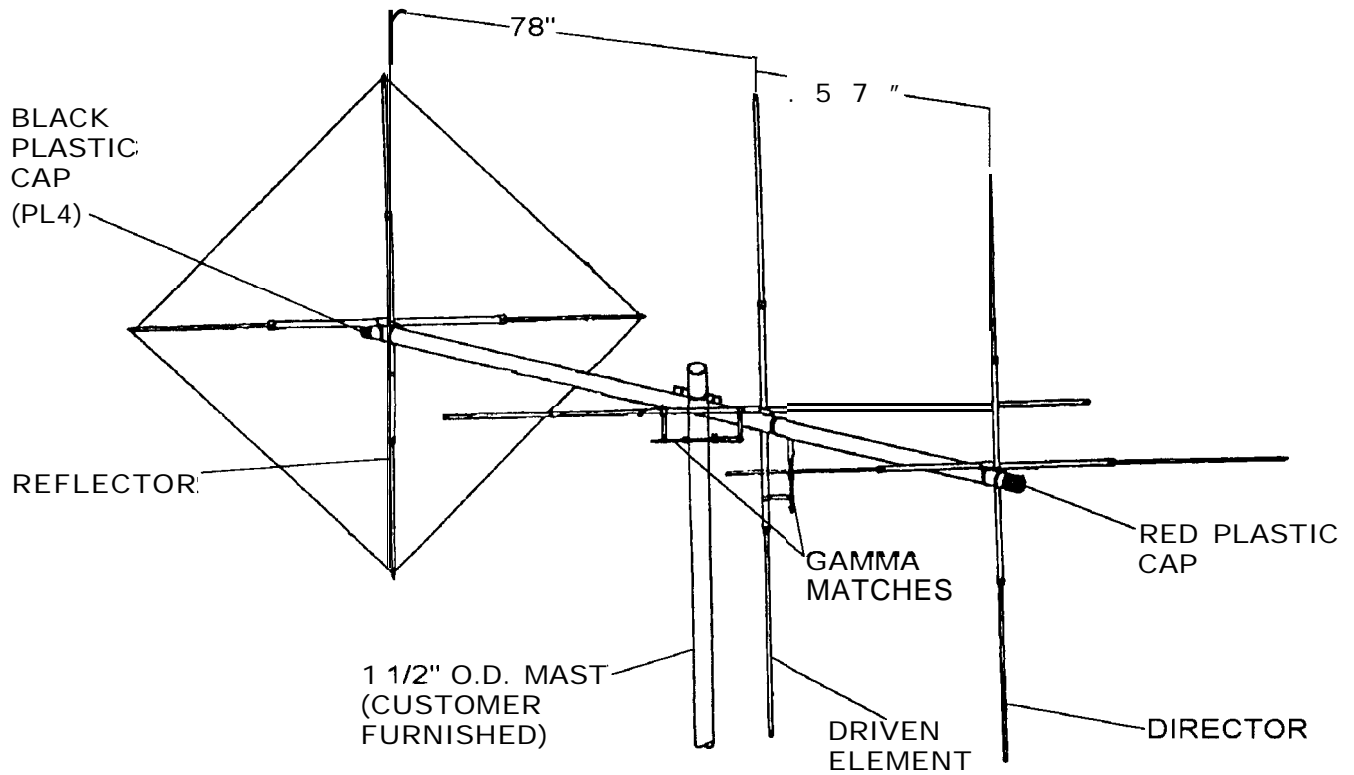

This figure shows what the antenna should look like when assembled. Specific assembly details are shown on following pages. All hardware should be tightened securely, and then coated with silicon rubber sealant or similar compound to prevent loosening from wind vibration .

Take care to locate all parts accurately per dimensions given. Complete each step as instructed before going onto the following steps.

After completing assembly, install red plastic cap (PL4R) on the director end of the boom, and the black plastic cap (PL4B) on the reflector end. This will enable you to tell at a glance the direction of transmit and receive.

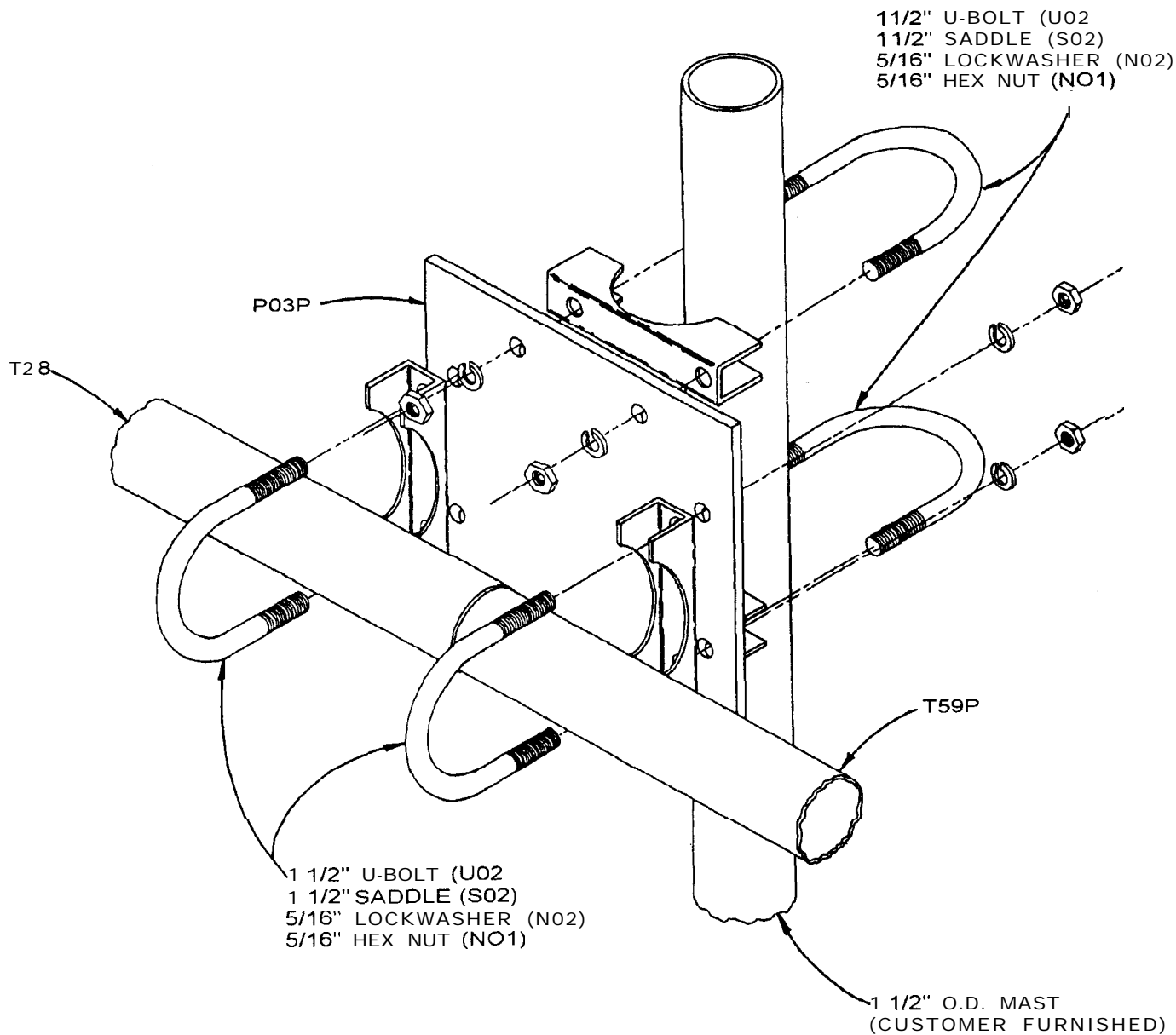

To assemble the boom slide the swaged ends of the boom section (T59P) 0.152m into the boom section (T28)

Mount the boom-to-mast plate (PO3P) to the boom using the 1 1/2" U-bolts, 1 1/2" saddles, and hardware shown.

This antenna is designed for mounting on a 1 1/2" O.D. mast. Mount using 1 1/2" U-bolts, 1 1/2" saddles, and hardware as shown.

Please read the Assembly and Troubleshooting Tips at the end of this instruction booklet before assembling elements.

ELEMENT	DIMENSION	
	A	B
DRIVEN	209"	68 1/2"
DIRECTOR	204"	66"
REFLECTOR	161 1/2"	44 3/4"

REFLECTOR DIMENSIONS ARE ONLY PRELIMINARY. CHANCE TO GET EQUAL SIDES OF 9' 6". FIBERGLASS LENGTH IS NOT CRITICAL, HOWEVER, THE EQUAL WIRE LENGTH OF 9' 6" IS VERY CRITICAL.

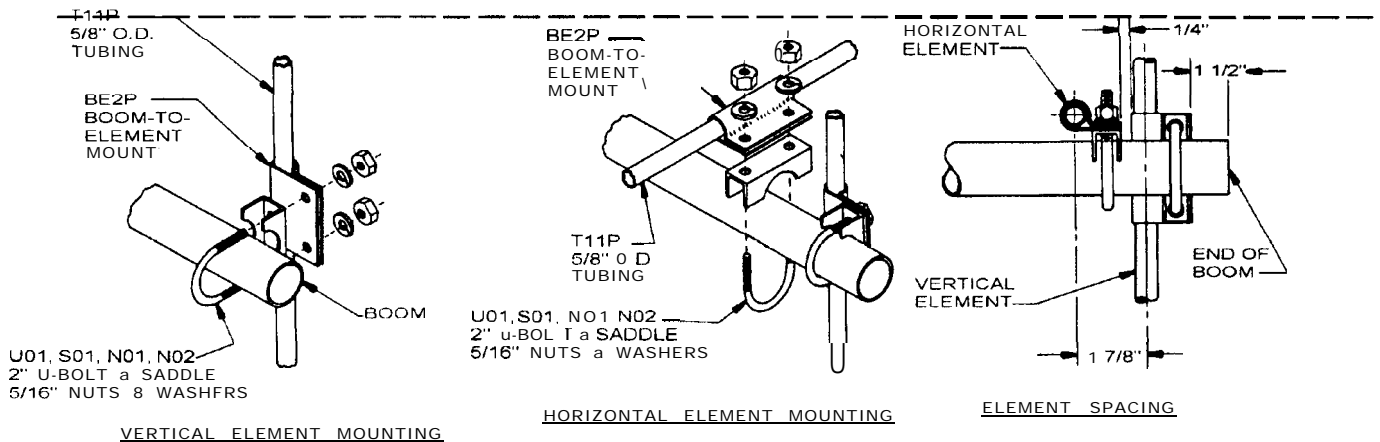
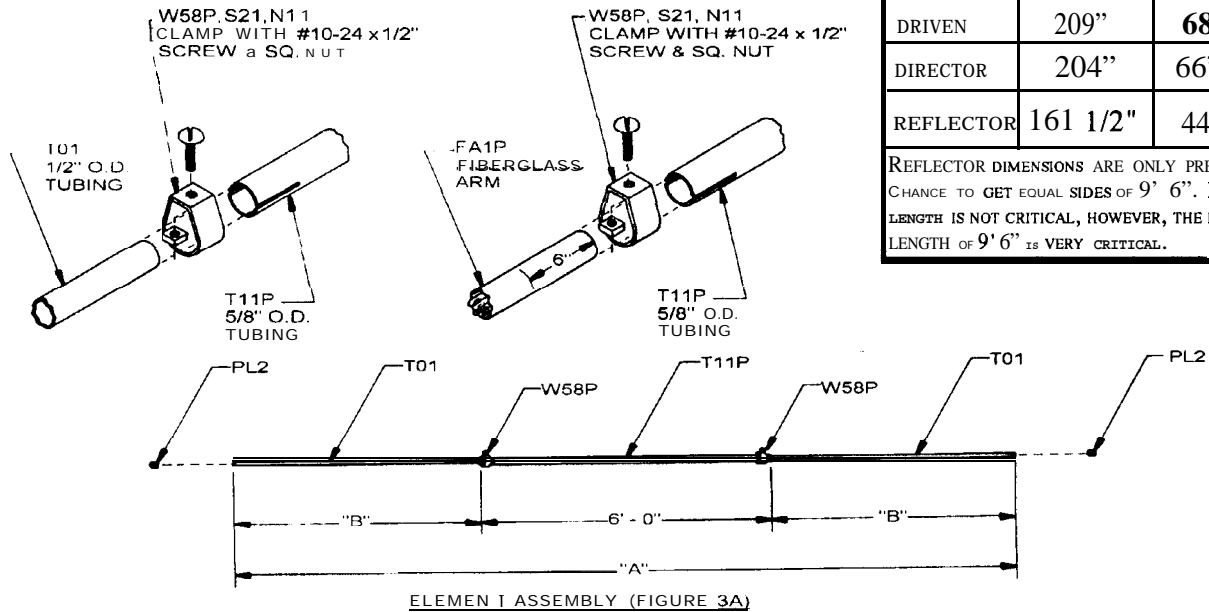

(FIGURE 3B)

The length of the reflector wire is very critical. It must be the correct length to operate correctly. Take the wire (W04P) and uncoil it making sure that there are no kinks; secure it to a nail. Pull the wire until it stretches an inch or so. The easy way to get the correct length for the reflector loop is as follows

1. Drive 2 nails in a board or fence 1/2 the length of the loop apart --which is 228" (5.790m) between them.

2. Stretch the wire around the nails by hand as tightly as possible and splice ends together. Solder the splice. Remove one nail and remove the loop. Cut any excess wire off.

3. Loosely assemble the machine screws (S21), flatwashers (N26), lockwashers (N12), and hex nuts (N06) onto the lugs of the fiberglass arms, adjusting the length as shown.

4. Tighten 3 of the 4 clamps that hold the fiberglass rods.

5. Install the wire as shown.

6. Tighten the wire by pulling the fourth fiberglass rod until the wire is the same tightness as it was around the nails. The wire loop is now the correct length. REFLECTOR DIMENSIONS ARE ONLY PRELIMINARY. CHANCE TO GET EQUAL SIDES OF 9' 6". FIBERGLASS LENGTH IS NOT CRITICAL, HOWEVER, THE EQUAL WIRE LENGTH OF 9' 6" IS VERY CRITICAL.

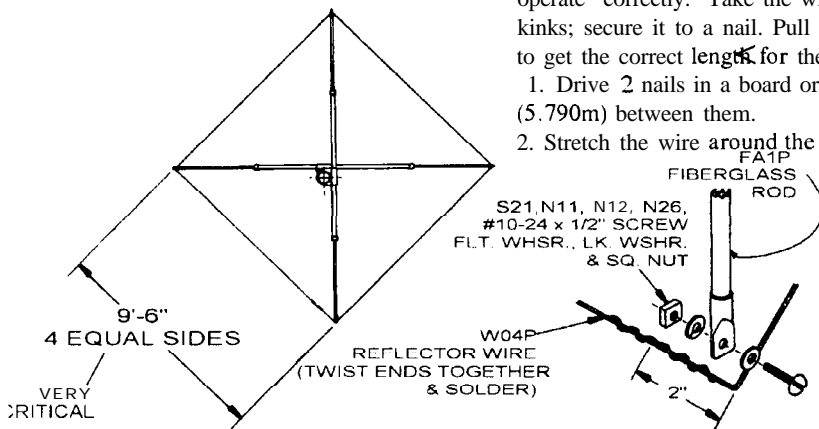

* **NOTE:** THESE DIMENSIONS ARE APPROXIMATE. REFER TO THE INSTRUCTIONS ON ADJUSTING THE S.W.R. TO DETERMINE EXACT SETTINGS. THERE ARE 2 SEPARATE GAMMA ADJUSTMENTS, 1. CAPACITOR ADJUSTMENT, 2. SLIDER POSITION.

DO NOT MOVE BOTH AT THE SAME TIME. MOVE THE CAPACITOR FIRST, THEN, IF NECESSARY MOVE THE SLIDER, AND GO BACK TO THE CAPACITOR.

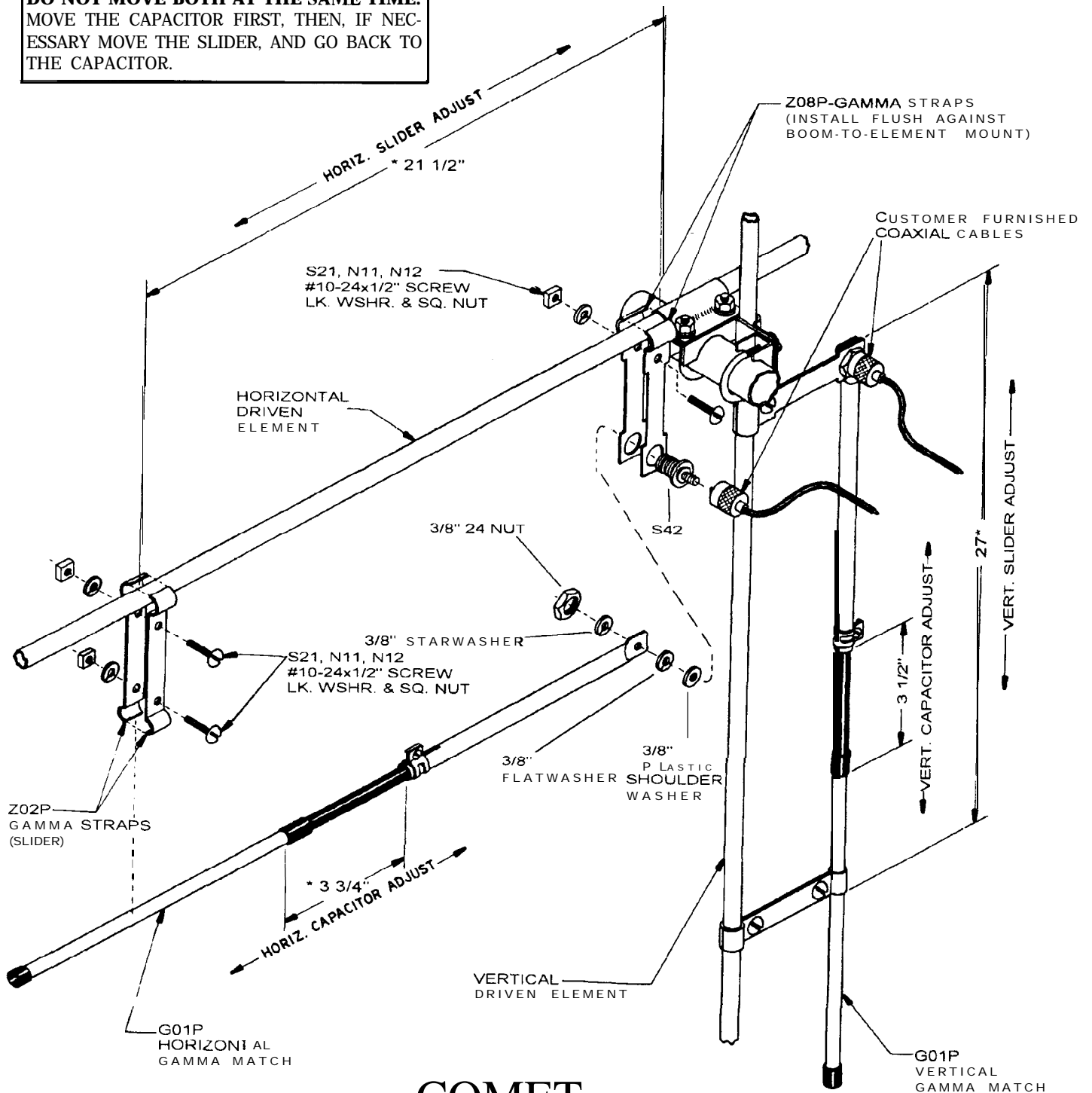

COMET GAMMA MATCH MOUNTING

COMET



**High Voltage
Overhead**



Caution:

**TAKE CARE TO AVOID ANY CONTACT WITH
OVERHEAD POWERLINES WHEN RAISING,
INSTALLING, OR REPAIRING YOUR
ANTENNA, TOWER, OR ROTOR.**

DEATH WILL OCCUR!

Installing and rigging towers, masts and antennas require specialized skills and experience. Information supplied by MACo assumes that all products will be installed by personnel having these skills and have installed similar products before. No one should attempt to install towers or masts without these knowledgeable skills.

MACo assumes no liability if faulty or dangerous installation practices are used. There are available, trained and experienced personnel to assist in installation, maintenance, or disassembly. Contact your local installer if consultation or assistance is required.

All tower and antenna installations should be thoroughly inspected at least twice a year by qualified, experienced, and trained personnel to insure proper performance and safety standards.

Electrical Warning

An additional warning precaution is given to be careful of surrounding high voltage power wires and other electrical hazards during installation of your tower, rotor, or antenna.

Do not erect a tower, rotor, or antenna during an electrical storm, rainstorm, or when lightning is a possibility.

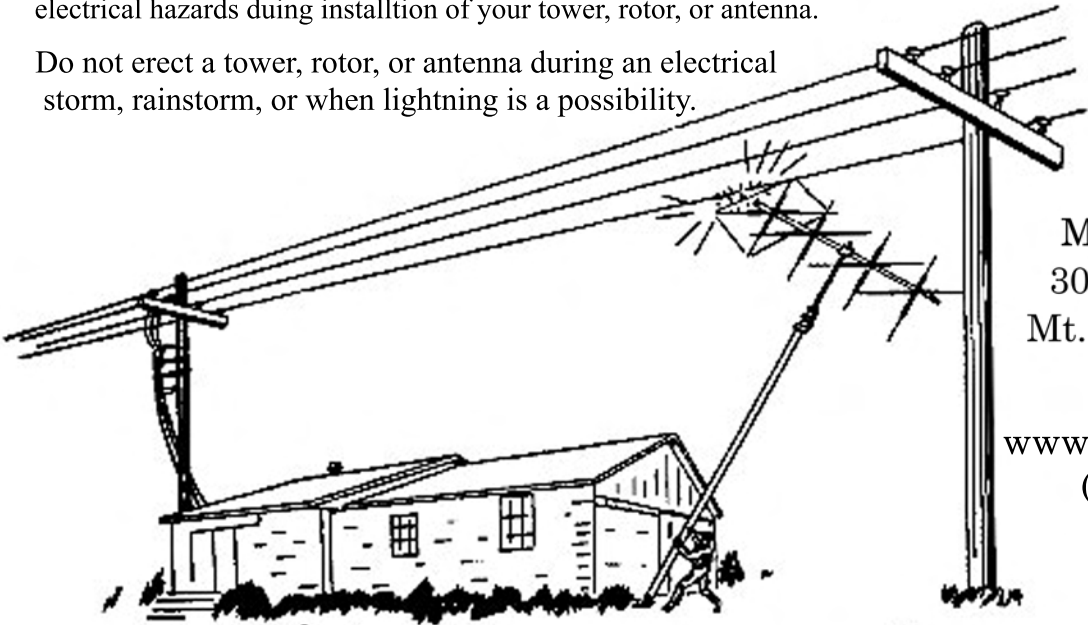

**MACo Antennas
302 S. East Street
Mt. Carroll, IL 61053**

www.macoantennas.net
(815) 244-3500