

MAT-TUNER[®]

mAT-M200 INSTRUCTIONS

Antenna tuner for the ICOM&KENWOOD transceiver

Thank you for choosing this ***MAT-TUNER*** product.

Please **READ ALL INSTRUCTIONS** carefully and completely before using this tuner.

■IMPORTANT

- ◆ **NEVER** touch the antenna or antenna connector with your hand when the transceiver is transmitting, it will cause burns!
- ◆ **NEVER** use the antenna tuner during a lightning storm. It may result in an electric shock, cause a fire or damage the tuner. Always disconnect the antenna before a storm.
- ◆ **NEVER** operate the tuner with its cover removed. Contact with the components inside the tuner while transmitting will result in painful RF burns.
- ◇ Always turn your radio off before plugging or unplugging anything. The radio may be damaged if cables are connected or disconnected while the power is on.
- ◇ The product is designed for indoor operation only, it is not water resistant. If you use it outdoors (Field Day, for example), you must protect it from rain, dew and steam.
- ◇ This tuner is a special model for ICOM and KENWOOD transmitters. We will try to make it match more models of transmitters. We can only guarantee that it can match the existing transmitter well. For the new transmitter to be sold by ICOM and KENWOOD company in the future, we can't guarantee that this tuner can also match well.

■INTRODUCTION

mAT-M200 is specially designed for ICOM and KENWOOD brand transmitters with RF power not higher than 200W_(SSB).

This tuner is also a great choice for users who like to operate the transmitter in digital modes such as FT8, CW and RTTY. For most tuners, it is not possible to withstand 100 watts of digital mode RF signals entering the tuner. The mAT-M200 allows up to 100 watts of digital mode RF signals to pass through the tuner.

mAT-M200 has a working frequency range of 1.8-54MHz and a maximum allowable RF power of 200 watts. As an external antenna tuner, it is connected to the ICOM transmitter via the control cable mAT-CI or to the KENWOOD

transmitter via the mAT-CK cable. The tuner comes with mAT-CI cable by default. The transmitter supplies power to the tuner through this cable, communicates with it and controls the operation of the tuner. The tuner does not require additional power supply. The tuner is compatible with ICOM and KENWOOD tuners, and users can easily control the tuner using the [TUNE] or [AT] buttons on the panel of the radio equipment. This makes the operation of the tuner very convenient.

For ICOM devices, the tuner only works with transmitters with a standard ICOM 4-pin tuner socket. If your transmitter doesn't have this socket, you won't be able to use it. If your transmitter has a non-standard 4pin ICOM tuner socket, such as IC-M710, M802, IC-F7000, IC-F8101, you will have to modify the mAT-CI cable so that it can be connected to the TUNER of these transmitters cable socket before you can use this tuner. The same goes for KENWOOD devices, but their TUNER socket is 6-pin. When the tuner is powered on and started, it will detect whether it is currently linked to an ICOM device or a KENWOOD device and automatically match it.

NOTICE: If you want to modify the control cable, be sure to read the operation manual of these transmitters carefully to confirm that the order of each pin of the cable is accurate. Incorrect modifications may damage the transmitter and tuner.

It will tune dipoles, verticals, Yagis, or virtually any coax-fed antenna. It will match an amazing range of antennas and impedances, far greater than some other tuners you may have considered, including the built-in tuners on many radios.

■ FRONT PANEL

The front panel of the tuner has 2 indicator lights, as shown in the figure.

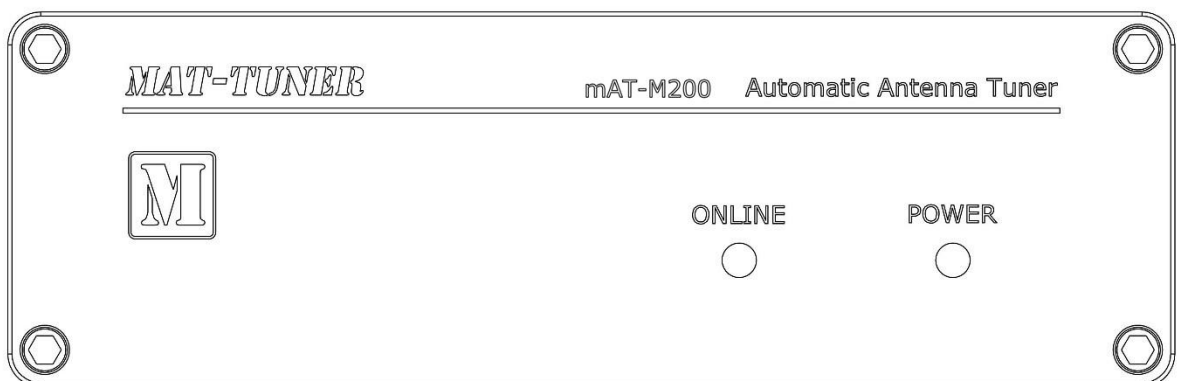

ONLINE: Status indication. Lights up to indicate that the tuner is

online, off-indicates that the tuner is bypass.

POWER: Power light

When the tuner is working, lit green.

■ **REAR PANEL**

The figure below is the rear panel of the tuner.

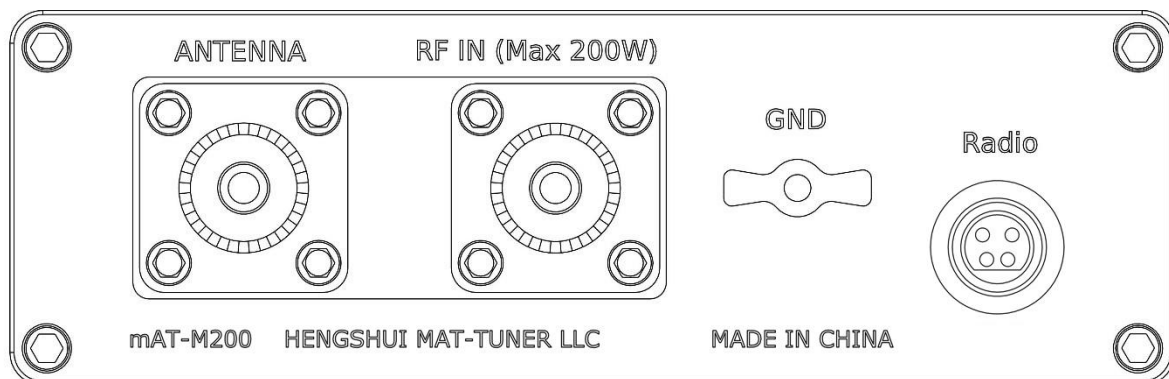

GND: Connected to antenna system ground. Correct and good ground wire can ensure the safe operation of the tuner.

ANTENNA: SO-239 socket, connect antenna with 50 ohm coaxial cable.

RF IN(Max 200W): SO-239 socket, connected to the transmitter's "ANT" socket, using 50 ohm coaxial cable.

Radio: This socket is connected to the transmitter's "tuner" socket through a 4-pin cable mAT-CI or mAT-CK. The mAT-CI cable comes with the tuner by default.

■ **INSTALLATION**

Which transceivers can use mAT-M200 Modern transmitters of ICOM and KENWOOD brand with RF power not higher than 200W, in FT8 mode, RF power is not higher than 100 watts. Of course, it can also be used for transmitters with RF power of 100W or lower.

Important: before connecting any cables, be sure to turn off the power of the transmitter.

Installation

1. Connect the "**ANT**" jack on the transceiver to the "**RF IN**" jack on tuner, using a 50 ohm coax cable rated 200 watts or greater.
2. Connect the control cable mAT-CI or mAT-CK(KENWOOD) to the 4-pin jack on tuner, marked "**Radio**".
3. Connect the other end of this mAT-CI or mAT-CK(KENWOOD) cable to the "**TUNER**" jack on the transceiver.

- Number of memories: 16000
- Usable temperature: -10°C ~ +60°C, 14°F ~ 140°F
- Dimensions: 180 x142x51mm, 7.1x5.6 x 2.0 inches
- Weight: 830g, 29.3oz

■ TECHNICAL SUPPORT

Visit the web: <http://www.mat-tuner.com/> for more information.

The website provides links to product manuals, just in case you lose this one! When you are thinking about the purchase of other **MAT-TUNER** products our website also has complete product specifications and photographs you can use to help make your purchase decision. Don't forget the links to all of the quality **MAT-TUNER** Dealers also ready to help you make that purchase decision.

HENGSHUI MAT-TUNER LLC
No.28 Ronghuabei ST, Hengshui, CHINA
E_mail: bg3mzu@gmail.com, mail@mat-tuner.com